

boomdesk™

interactive sound + mega storage

battery powered

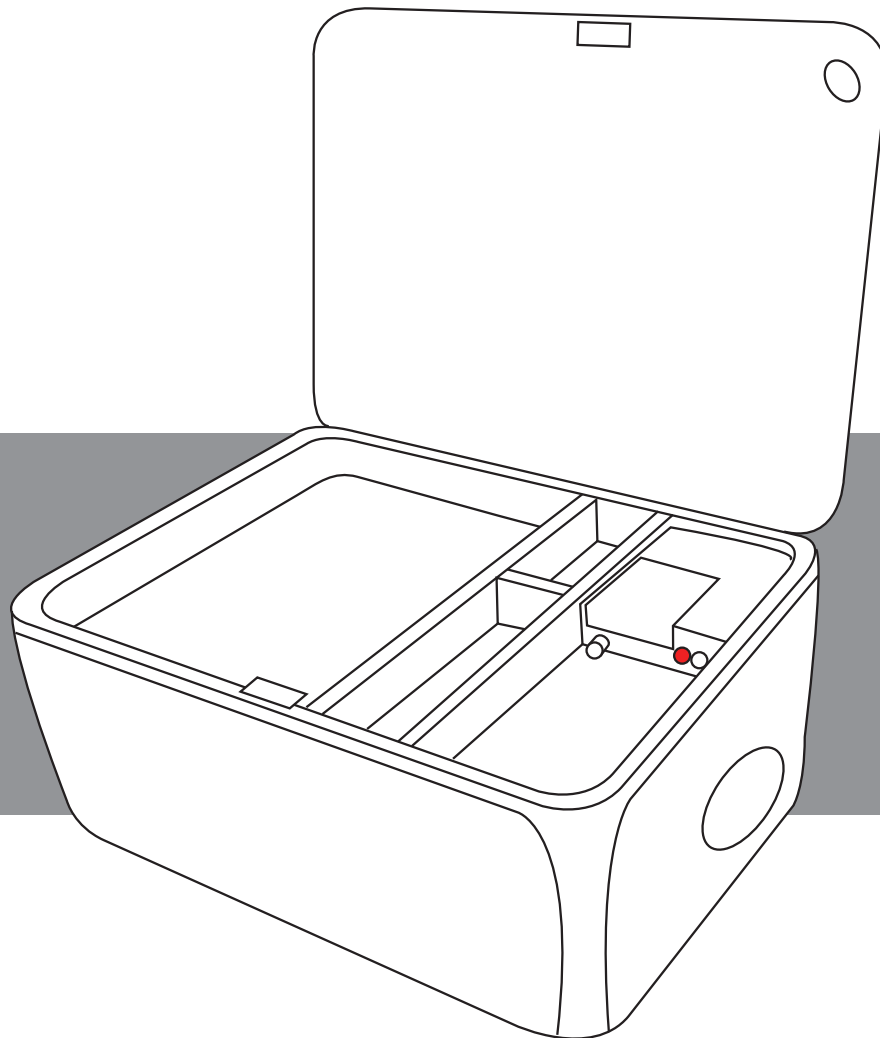

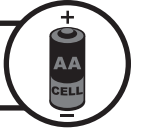

CAUTIONS

READ BEFORE USE

- DO NOT wash or soak with water. If BoomDesk™ gets wet, disconnect power immediately and do not use until completely dry.
- Switch power off on Speaker Lap Desk when not in use.
- Children under 5 years old should not use this product without parental supervision.
- For INDOOR use only. DO NOT expose to direct sunlight, moisture, or extreme temperatures.
- Excessive exposure to audio equipment at high volume may lead to hearing loss.
- DO NOT open any section other than the battery cover on the BoomDesk™. There are no user serviceable parts inside. Refer to Maintenance and Repair section below for service information
- DO Not Mix Old And New Batteries. Do Not Mix Alkaline, Standard (Carbon - Zinc), Or Rechargeable (Nickel - Cadmium) Batteries.
- To avoid explosion or leakage, do not dispose of batteries in a fire or attempt to recharge standard or alkaline batteries. Please dispose of batteries safely according to the battery manufacturers instructions or recycle battery per state and local codes. If battery leakage occurs and comes in contact with the skin or eyes, wash immediately with plenty of water. Batteries should be handled under adult supervision. If the device is not to be used for a long period of time, remove the batteries to prevent injury from possible battery leakage.

NOT RECOMMENDED FOR USE IN VEHICLES.



TROUBLESHOOTING BOOMDESK™

Q: Why is there no sound?

A: Ensure your BoomDesk™ is connected as described in the Operation Instructions, and 4 fresh “AA” batteries are correctly installed. Check that the power is on. There is no volume control on the BoomDesk™. Control volume using the volume adjustment of the connected device. Make sure your connected device has the volume all the way up.

Q: Why isn't there sound coming from one of the speakers?

A: Ensure the audio cord to the BoomDesk™ is securely connected as described in the Operation Instructions. Make sure that both the left and right channel audio inputs are securely connected to both the BoomDesk™ and audio device.

Q: Where can I get more information?

A: Visit us at www.BOOMCHAIR.com or www.LumiSource.com

Contact information: LumiSource, Inc. 2950 Old Higgins Road, Elk Grove Village, IL 60007

E-mail: customerservice@lumisource.com

MAINTENANCE AND REPAIR

If a problem occurs while using this product, please contact us at 1-866-472-0500. DO NOT open unit or attempt to repair on your own. It may result in serious injury from electric shock.

CLEANING/CARE INSTRUCTIONS

Fabric: Use a clean cloth to dab lightly with soap and water.

DO NOT rub.

DO NOT immerse in water.

DO NOT use detergent.

SET-UP GUIDE

The BOOMDESK™ comes with the following:

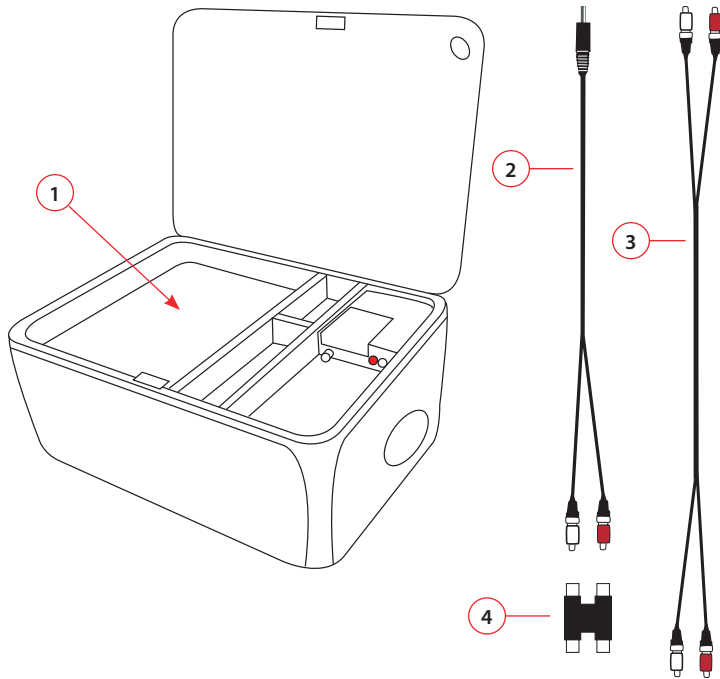

PARTS LIST

- 1) BOOMDESK™
- 2) RCA TO MINI AUDIO CORD
- 3) RCA CORD
- 4) RCA AUDIO COUPLER

POWER

- Step 2: Slide open battery compartment (A).
- Step 3: Insert 4 "AA" cell batteries (not included).
- Step 4: Close battery compartment securely.
- Step 6: Turn BOOMDESK™ on by pushing Power button (B).

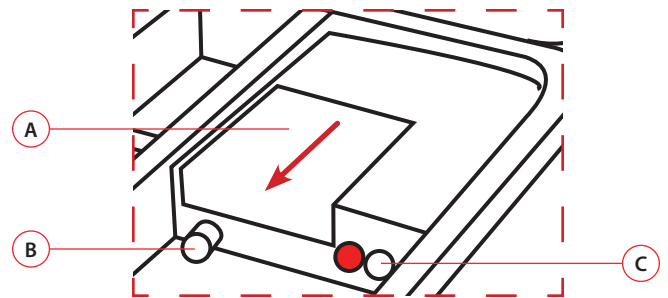

(High quality Alkaline batteries recommended)

CONNECTING TO PORTABLE AUDIO / VIDEO DEVICES

- Step 1: Connect the Red/White ends of RCA cord (2) into RCA INPUT (C) of BOOMDESK™.
- Step 2: Plug the single end of the RCA cord (2) into the headphone jack of your device.
- Step 3: Turn BOOMDESK™ on by pushing Power button (B).
- Step 4: Turn portable device on.

Note: There is no volume control on the Boomdesk. Control volume using the volume adjustment of the connected device.

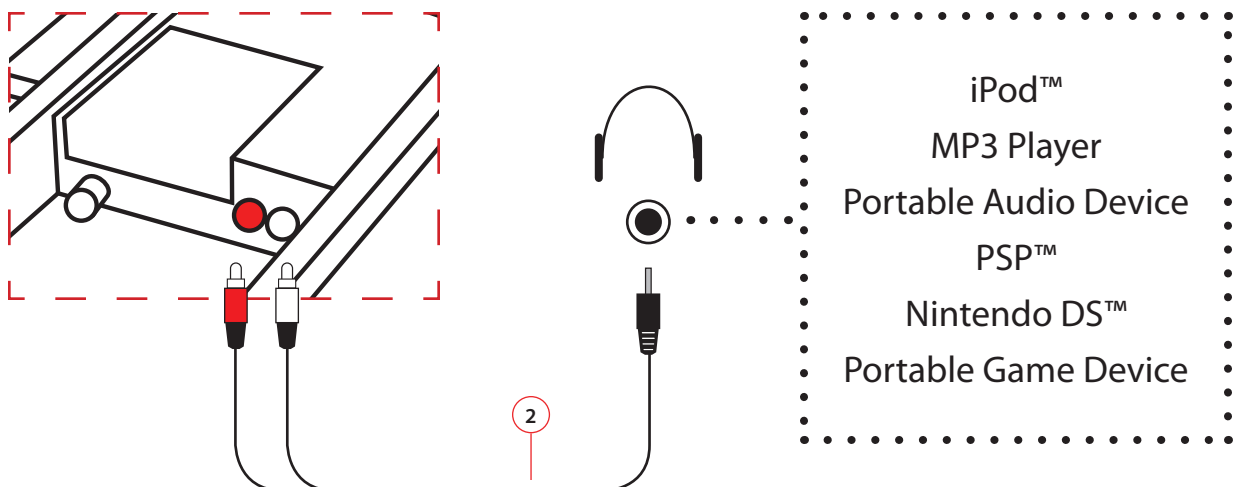

LUMISOURCE, INC. LIMITED WARRANTY

LIMITED WARRANTY: LumiSource, Inc. ("LumiSource") warrants this product against defects in materials and workmanship for a period of ninety (90) days from the date of original consumer purchase. If a covered warranty claim is timely made, LumiSource® will, at its sole discretion: (a) repair the product, using new and/or refurbished replacement parts or (b) replace the product with an identical (or comparable) product, without charge to you other than the initial shipping cost to return the product. LumiSource® will only pay return shipping charges for destinations within the 48 contiguous U.S.A., if the returned product is covered by the limited warranty.

WHAT THIS WARRANTY DOES NOT COVER: This warranty does not cover defects resulting from accidents, alterations, unauthorized repair, failure to follow instructions, misuse, commercial use, fire, flood, or acts of God.

WHAT WE ASK YOU TO DO: If there is a covered defect, please write or email us within 90 days of the date of purchase at the address noted on page 8 to obtain instructions and authorization to return the product to LumiSource®. You will need to pack the product securely in packaging providing at least the degree of protection of the original carton and packing materials and ship it to us at your expense. You will also need to include with the product (a) a copy of your original proof of purchase (retail receipt) showing the date of purchase and (b) a detailed explanation of the problem(s) requiring service.

TO THE EXTENT PERMITTED BY LAW, THIS LIMITED WARRANTY AND THE REMEDIES SET FORTH ABOVE ARE EXCLUSIVE AND IN LIEU OF ALL OTHER WARRANTIES, REMEDIES AND CONDITIONS, ORAL OR WRITTEN, EXPRESS OR IMPLIED. TO THE EXTENT PERMITTED BY LAW, LUMISOURCE® HEREBY DISCLAIMS ANY IMPLIED WARRANTIES, INCLUDING WITHOUT LIMITATION, WARRANTIES OF MERCHANTABILITY AND FITNESS FOR A PARTICULAR PURPOSE. TO THE EXTENT APPLICABLE STATE LAW EXCLUDES SUCH DISCLAIMERS, THEN TO THE EXTENT ALLOWED BY LAW, THE TIME FOR ANY CLAIMS FOR SUCH IMPLIED WARRANTIES SHALL EXPIRE 90 DAYS FROM THE DATE OF ORIGINAL CONSUMER PURCHASE. TO THE EXTENT PERMITTED BY LAW, LUMISOURCE® IS NOT RESPONSIBLE FOR DIRECT, SPECIAL, INCIDENTAL OR CONSEQUENTIAL DAMAGES, INCLUDING BUT NOT LIMITED TO LOSS OF TIME, INCONVENIENCE, LOSS OF USE OF YOUR PRODUCT, OR PERSONAL INJURY OR PROPERTY DAMAGE, CAUSED BY YOUR PRODUCT OR ITS FAILURE TO WORK.

This limited warranty gives you specific legal rights. Some states do not allow the exclusion or limitation of incidental or consequential damages, and applicable law may not permit the exclusion of certain implied warranties. You may also have their rights, which vary, from state to state.

LumiSource, Inc.

2950 Old Higgins Road, Elk Grove Village, IL 60007

E-mail: customerservice@lumisource.com

Phone: 1-888-461-5864 (toll free)

Phone: 1-847-699-8988 (international)

www.BoomChair.com • www.LumiSource.com

© 2008 LumiSource, Inc. All rights reserved. BOOMDESK™, the BOOMDESK™ logo, and the Boom logo are trademarks of LumiSource Inc. Other trademarks are properties of their respective owners. The design of this product is a trade dress of LumiSource, Inc. Patents pending. Actual contents may differ slightly from those pictured. Made in China. Distributed by LumiSource Inc., 2950 Old Higgins Road, Elk Grove Village, IL 60007. www.lumisource.com.

This product is not manufactured or distributed by Microsoft®, the owner of the trademark Xbox™; by Nintendo®, the owner of the trademark Wii™, GameCube™, and DS™; by Sony®, the owner of the trademarks Playstation™ PS3™, PS2™, and PSP™; or by Apple Computer, Inc., the owner of the trademark iPod™.